



# PRIMARY INJECTION CIRCUIT BREAKER TEST SET



## INSTRUCTION MANUAL

### Models

PI-800-GEN2 and PI-1600-GEN2

Electrical Test Instruments, LLC  
8430 Spires Way, Suite A  
Frederick, MD 21701

[www.etiprecision.com](http://www.etiprecision.com)

p (410) 857-1880  
f (410) 857-1387

## TABLE OF CONTENTS

### SECTION I: GENERAL INFORMATION and SPECIFICATIONS

WARNING	I-1	
Introduction	I-2	
General Description	I-2	
Monitor and Controller MAC-21	I-5	
Advantages Compared to Other Test Sets	I-6	
Trademarks	I-6	
MAC-21 Specifications	I-7	
PI-800 GEN2 Specifications		I-8
PI-1600 Specifications	I-9	

### SECTION II: DETAILED DESCRIPTION

Theory of Operation		
High Current Test Sets	II-1	
PI-800 GEN2 Main Circuitry		II-1
PI-AUX Boost Unit Circuitry	II-3	
Major Parts Identification and Operation	II-3	

### SECTION III: MAC-21 Monitor and Controller

MAC-21 Specifications	III-1	
MAC-21 Unit Circuitry	III-2	
MAC-21 Software	III-2	
MAC-21 Parts Identification and Operation	III-4	
MAC-21 Internal Parts	III-8	
Figure II-1: Front Panel	III-9	
Maintenance and Calibration of MAC-21	III-10	
Parts List (MAC-21)	III-12	
Overall Schematic (MAC-21)	III-13	

### SECTION IV: OPERATING INSTRUCTIONS

Pre-Test Installation and Setup	IV-1	
Output Connection Diagram	IV-2	
Basic Guidelines and Suggestions	IV-3	
Duty Cycle Ratings	IV-3	
Single Pole Molded Case Breakers	IV-5	
Multi-pole Molded Case Breakers	IV-8	
Low Voltage Power Breakers	IV-11	
Motor Overload Relays	IV-15	

Ratioing Current Transformers

IV-17

SECTION V: SERVICE INFORMATION AND DOCUMENTATION

Maintenance and Calibration of PI-800 GEN2/1600	V-1
Maintenance and Calibration of MAC-21	V-1
Parts List (PI-800 GEN2)	V-4
Parts List (PI-AUX)	V-5
Warranty	V-6
Overall Schematics	END

## SECTION I

### GENERAL INFORMATION and SPECIFICATIONS

#### **WARNING**

WARNING - READ THIS ENTIRE MANUAL AND THOROUGHLY FAMILIARIZE YOURSELF WITH THE UNIT OPERATION PRIOR TO CONNECTING THE UNIT TO A SOURCE OF POWER. HIGH CURRENT TEST SETS ARE NORMALLY POWERED FROM HIGH CAPACITY 208 VOLT TO 575 VOLT SERVICES, AND IMPROPER CONNECTION OR OPERATION COULD CAUSE DAMAGE TO THE TEST SET AND EQUIPMENT UNDER TEST, AS WELL AS CREATE AN UNSAFE CONDITION FOR PERSONS OPERATING THE SET.

### INTRODUCTION

A primary injection test set, such as the **PI-800 GEN2** and **PI-1600 GEN2**, is a device with high current, low voltage AC outputs for testing direct acting low voltage circuit breakers. Current is injected through the main contacts of the breaker to simulate actual fault conditions, which tests the operation of CTs, solid state, thermal, or electromechanical trip devices, and the actual trip mechanisms and breaker contacts.

### GENERAL DESCRIPTION

The **PI-800 GEN2/1600** Circuit Breaker Test System incorporates modular design and flexibility to provide unequaled capability in a portable package. The **PI-800 GEN2** used alone, generates continuous current of 400, 800, or 1600 amps at **4.2 kVA**, with peak output to over 10x. The **PI-Aux** boosts total power to **9.8 kVA**, and allows testing of drawout breakers and MCBs to **1600 A**. The units are housed in rugged interlocking suitcase-size enclosures. Each piece weighs no more than **125 pounds**, allowing one-person hand truck mobility. Basic operation is very simple, and the proven **MAC-21** provides optimal output control and measurement.

The **PI-800 GEN2** is a versatile and technologically advanced **portable** primary injection test set capable of testing circuit breakers up to **800 amperes** frame size. It incorporates a special lightweight toroidal output transformer with dual primaries, and quad secondaries to provide optimal impedance matching to a wide range of breaker sizes. **Internal fan cooling** allows maximum utilization of the output transformer and faster recovery after overload conditions.

The **PI-800 GEN2** consists of a strong stainless-steel frame, housed in a rugged plastic and aluminum enclosure with removable sealed front and back lids for maximum protection of controls and indicators, as well as storage for test leads, manuals, etc. All controls, indicators, and input connections are on the front panel. The versatile 50-amp input plugs may be connected to heavy duty portable cords with a variety of connectors for 120 VAC, 208 VAC, or 240 VAC. Individual leads may also be used to connect to buswork. The output connections are on the rear, along with an auxiliary Output ON indicator, configuration switch, and air output from the fans, which can help cool cables and breakers. Comfortable recessed side handles provide ease of mobility.

The **MAC-21** is supplied in a separate rugged portable case, interlocks on top of the **PI-800 GEN2**, and connects to a cable in the rear of the test set.

The eight-silver plated output bus connectors allow configuration for continuous outputs of **800 amperes** at **4.2 VAC**, and **400 amperes** at **8.4 VAC**, for testing molded case breakers with cables. They can also be connected for **1600 amperes** at **2.1 VAC**, which can be used for CT testing, heat runs of bus connections and limited testing of air drawout breakers. They have pressed-in 3/8"-16 stainless steel threaded inserts, which eliminates the need for nuts, and the

## Electrical Test Instruments PI-800 GEN2 and PI-1600 GEN2

configuration bars are slotted for quick and easy changing for various breaker sizes.

The *PI-Aux* is a booster unit which connects to the *PI-800 GEN2* and *MAC-21* to create a powerful two-piece test system for medium size air drawout and molded case breakers up to **1600 amperes** frame size. It also consists of a strong aluminum frame, housed in a rugged plastic and aluminum enclosure with removable sealed front and back lids. The output connections are on the rear, along with an auxiliary Output ON indicator, and air output from the fans, which can help cool cables and breakers. Comfortable recessed side handles provide ease of mobility.

For the *PI-1600 GEN2*, the *PI-800 GEN2* is placed in interlocking ridges on top of the *PI-Aux* and interconnected by means of simple control and power cables. The *MAC-21* connects to the *PI-800 GEN2* by means of a single cable, which allows it to be placed in the interlocking ridges of the *PI-Aux* for a three-piece stacked unit. The outputs are connected by means of two slotted bus bars, and four connection plates. A series bar is supplied for continuous current of **800 amps** at **10 VAC** for testing smaller breakers that require connection via cables. Larger breakers may be tested by connecting up to six cables in parallel, for continuous current of **1600 amps** at **5 VAC**. It is also possible to configure the output for **400 amps** at **20 VAC** for connection to small breakers with long cables. A selector switch adjusts the internal CT output for proper readings in each of the three configurations.

stab mounting plates may be bolted to the *PI-1600 GEN2* as required to provide connection to standard Stabs, with a *true continuous* output current rating of **1600 amperes** at **5 VAC**. Strong, easily replaceable stainless steel bolts allow maximum torque to be applied without concern about breakage or rotation of studs. The edges of the stab mounting plates provide solid mechanical bracing to the output plates of the two units, and breakers may be racked in without worrying about bending the buswork.

Standard silver-plated copper Stabs are designed to be used both vertically and horizontally, they are available with  $\frac{1}{2}$ " or  $\frac{3}{4}$ " blades.

The test set comes with 2 input voltage options.

Option A: 120, 208-240VAC

Option B: 208, 240, 277VAC

Voltage selection is provided by means of a simple selector switch on the *PI-800 GEN2* front panel. An **internal voltage sensor** prevents the main power from being turned on if the input voltage is incorrect.

The vernier uses a simple knob to adjust the output manually within the range determined by the coarse tap. Clockwise rotation always increases output, which reduces confusion.

A convenient rotary switch selects the coarse tap. It activates relays in either the

*PI-800 GEN2* or *PI-Aux* to provide 7 ranges of output for the *PI-1600 GEN2* combined unit.

The indicator/control panel features:

- (1) An **Input Voltage** indicator, which lights whenever power is connected to the test set
- (2) A green **Control Power ON** switch/indicator, which also turns on the main output power
- (3) An amber **Output ON** indicator, which lights when output is initiated.
- (4) A red **Interlock Indicator**, which lights if control power is off, or if an interlock open condition exists. It also functions as an output shut-down switch, which turns off main power.
- (5) Three **System Status LEDs**, which provide information on the internal temperature of the buswork, as well as duty cycle limitations of the vernier.
- (6) Three **Output LEDs**, which show overcurrent usage of the test set, from 1x to 10x.
- (7) A **Bus Overtemperature** indicator on the rear, which lights if any bus connection overheats.

Primary catastrophic overload protection for the test set is accomplished with input fuses having high interrupting current capacity. Overload of the output system is sensed by means of a **Programmable Overload Detector (POD)** on the vernier autotransformer. The **POD** allows full utilization of the overload capability of the test set and eliminates costly and cumbersome fuse replacement required in other test sets. It senses actual temperature of the output bus, as well as duty cycle overload use of the vernier, and provides visual indication by means of green, yellow, and red LEDs. It will shut down the test set output if extreme overloads or overtemperatures are detected and will inhibit re-initiation until there has been sufficient cooling time.

The output of the test set is controlled by means of a **proven SCR controller**. This provides precise initial phase angle control to reduce DC offset for inductive loads and more consistent pulse currents.

The measurement of output current and time is accomplished by means of the proven **MAC-21**, which uses highly accurate A/D circuitry and intelligent firmware to resolve true-RMS values of distorted waveforms. It also provides features such as preset ON times for convenient jogging of output current without overheating the breaker or causing unwanted trips.

The **MAC-21** is also capable of reading **Peak RMS current**, which can help detect waveform distortion on fast trips, as well as **Last RMS current**, which is useful for pickup tests. Either value may be displayed after the test is completed. Normally, the **MAC-21** displays the true RMS value of the entire waveform, regardless of duration.

## Electrical Test Instruments PI-800 GEN2 and PI-1600 GEN2

The entire test set has been designed for reliability, ruggedness, reasonable portability, and ease of use. Sophisticated electronics in the **MAC-21** provide state of the art accuracy and convenience, while simple connections allow for easy disassembly for transportation or service.

### MONITOR AND CONTROLLER MAC-21

The MAC-21 microprocessor-based measurement and control unit features **digital** readout of current and time enhanced by digital signal processing. Pulse (memory) mode provides fast and accurate automatic evaluation of output current pulses as short as one-half cycle.

The MAC-21 incorporates a precision A/D converter and special firmware for true-RMS continuous and pulse current reading with much greater accuracy. It also utilizes a sophisticated current sensing system for more reliable current latch mode operation and better timing accuracy. An LED digital readout for current in four ranges from 1000 A to 100 KA.

An integral auto ranging timer with LED readout provides four digits in seconds or cycles mode, with a resolution of 0.001 second or 0.1 cycle. A **preset** function allows you to set a maximum ON time in seconds or cycles, for convenient "jogging" of output to desired current or setting time for heat runs and long-time tests.

The memory current displayed after a test indicates the true RMS value of the entire pulse, no matter how long or short it was. Additionally, it is possible to read the **peak RMS value**, which indicates the amount of DC offset or distortion, or the **last displayed average RMS** reading, which is useful for pickup testing.



### ADVANTAGES COMPARED TO OTHER TEST SETS

Several changes have been made in the design of high current test sets since early models such as the EIL BTS-50, many of which are important for safety and convenience of operation.

The oldest test sets, made by companies such as Multi-Amp and EIL, used large variable autotransformers and high current step-down transformers to generate high current output. Tapped autotransformers provided coarse steps for several ranges of output current, as well as selectable input voltage. These old test sets used large, heavy iron-core CTs to measure output current with iron vane analog meters, often with pointer preset mechanisms to read current pulses. Times were displayed on electromechanical timers, suitable only for long time measurement.

Later test sets were improved by the use of air core current sensors, and various electronic instruments to measure current and time. These devices include the Duffers current meter, which was essentially peak responding, and the improved Accu-Amp, which used analog true-RMS circuitry and sample/hold technology. Similar circuitry was incorporated in the Multi-Amp Mem-Amp.

A major change in transformer design, incorporating multiple primary cores and dual secondary busses, provided greater efficiency and lower overall weight and size, but required a single input voltage.

The PLC-2000 used in the EIL PS-250 and PS-600 used a microprocessor to provide some advanced functions such as auto jog and current hold, as well as data collection and printout, but it was hard to use. Moreover, its current measurement circuitry was essentially analog, and did not provide accurate true RMS readings.

The Phenix Technologies' HC-30 and HC-100 used a PC compatible computer and real time data analysis software to provide some improvement, but it was also hard to use and suffered from reliability problems due to its complexity.

The MAC-21 Monitor Ammeter Controller used in the *PI-800 GEN2* and *PI-1600 GEN2* has been used with great success in many retrofits of older test sets. It has been refined to be highly accurate, reliable, and easy to use. The overall design of the test set incorporates advanced features which allow use on several input voltages without external transformers.

### TRADEMARKS

1. "Duffers" refers to a device manufactured by Duffers Corporation
2. "Accu-Amp" is a trademark for a device originally made by EIL Instruments, Inc.

### SPECIFICATIONS

## MAC-21 Monitor Ammeter Controller

CURRENT RANGES: 0-1000 A / 5 kA / 25 kA / 100 kA

CURRENT ACCURACY: +/- 0.5% of reading + 0.5% Full Scale (Continuous)  
+/- 1% of reading + 1% Full Scale (Pulse)

TIMER RANGES: 0-9999.999 Seconds / 0-9999.9 Cycles

TIMER ACCURACY: +/- 0.5% of reading +/- 1 count

DIMENSIONS & WEIGHT: Height: 8.5 in. (216 mm)  
Width: 19.5 in (495 mm)  
Depth: 13.0 in. (330 mm),  
23.0 in (584 mm) with lids  
Weight: 15 lb. (6.8 kg)

## Electrical Test Instruments PI-800 GEN2 and PI-1600 GEN2

### PI800 GEN2

#### OPTION A INPUT SUPPLY:

120 or 240 VAC + 10%, -15% (Switch Selectable), SINGLE PHASE  
 60 HZ (50 Hz at 10% lower maximum line voltages)  
 4.2 KVA (Continuous) at 3.8 KVA output (90% efficiency)

#### PI-800 GEN2 OUTPUT CURRENT & OVERLOAD CAPABILITIES:

4.2V (S/P)	8.4 V (Ser)	Ovld	Duty	Max ON Time *	Min OFF Time	Max Inp Curr (@240/120)
800 A	400 A	1x	100%	CONTINUOUS	N/A	18 / 36
1120 A	560 A	1.4x	50%	15 Minutes	15 Minutes	25 / 50
1600 A	800 A	2x	25%	5 Minutes	15 Minutes	36 / 72
2400 A	1200 A	3x	10%	2.5 Minutes	20 Minutes	50 / 100
3200 A	1600 A	4x	6%	75 Seconds	20 Minutes	72 / 144
4000 A	2000 A	5x	4%	4 Seconds	2 Minutes	90 / 180
5600 A *	2800 A *	7x	2%	2 Seconds	2 Minutes	126 *
8000 A *	4000 A *	10x	1%	0.6 Second	1 Minute	180 *

\*Available with 240 VAC input only; Max ON Times may be less at 120 VAC

\*\*Maximum output current possible into short circuit with very low source impedance

#### OPTION B INPUT SUPPLY:

208, 240 or 277 VAC + 10%, -15% (Switch Selectable), SINGLE PHASE  
 60 HZ (50 Hz at 10% lower maximum line voltages)  
 4.2 KVA (Continuous) at 3.8 KVA output (90% efficiency)

#### PI-800 GEN2 OUTPUT CURRENT & OVERLOAD CAPABILITIES:

4.2V (S/P)	8.4 V (Ser)	Ovld	Duty	Max ON Time *	Min OFF Time	Max Inp Curr (@277/240/208)
800 A	400 A	1x	100%	CONTINUOUS	N/A	16 / 18 / 21
1120 A	560 A	1.4x	50%	15 Minutes	15 Minutes	22 / 25 / 29
1600 A	800 A	2x	25%	5 Minutes	15 Minutes	31 / 36 / 42
2400 A	1200 A	3x	10%	2.5 Minutes	20 Minutes	43 / 50 / 58
3200 A	1600 A	4x	6%	75 Seconds	20 Minutes	62 / 72 / 83
4000 A	2000 A	5x	4%	4 Seconds	2 Minutes	78 / 90 / 104
5600 A *	2800 A *	7x	2%	2 Seconds	2 Minutes	109 / 126 / 146
8000 A *	4000 A *	10x	1%	0.6 Second	1 Minute	155 / 180 / 208

\*\*Maximum output current possible into short circuit with very low source impedance

## Electrical Test Instruments PI-800 GEN2 and PI-1600 GEN2

### PI-1600 GEN2

#### Option A INPUT SUPPLY:

240 VAC + 10%, -15%, SINGLE PHASE  
60 HZ (50 Hz at 10% lower maximum line voltages)  
9.8 KVA (Continuous) at 8.8 KVA output (90% efficiency)  
(Note: Specifications include required PI-800 GEN2 unit)

#### PI-1600 GEN2 OUTPUT CURRENT & OVERLOAD CAPABILITIES:

5.0V (Par)	10 V (Ser)	Ovld	Duty	Max ON Time *	Min OFF Time	Max Inp Curr (@240V)
1600 A	800 A	1x	100%	CONTINUOUS	N/A	37
2250 A	1125 A	1.4x	50%	15 Minutes	15 Minutes	52
3200 A	1600 A	2x	25%	5 Minutes	15 Minutes	74
4800 A	2400 A	3x	10%	2.5 Minutes	20 Minutes	111
6400 A	3200 A	4x	6%	75 Seconds	20 Minutes	148
8000 A	4000 A	5x	4%	4 Seconds	2 Minutes	185
11200 A	5600 A	7x	2%	2 Seconds	2 Minutes	259
16000 A	8000 A	10x	1%	0.6 Second	1 Minute	370
25000 A **	12500 A **	15x	0.5%	0.1 Seconds	1 Minute	555 **

\*\*Maximum output current possible into short circuit with very low source impedance

#### Option B INPUT SUPPLY:

208, 240 or 277VAC + 10%, -15%, SINGLE PHASE  
60 HZ (50 Hz at 10% lower maximum line voltages)  
9.8 KVA (Continuous) at 8.8 KVA output (90% efficiency)  
(Note: Specifications include required PI-800 GEN2 unit)

#### PI-1600 GEN2 OUTPUT CURRENT & OVERLOAD CAPABILITIES:

5.0V (Par)	10 V (Ser)	Ovld	Duty	Max ON Time *	Min OFF Time	Max Inp Curr (@208V/240V/277V)
1600 A	800 A	1x	100%	CONTINUOUS	N/A	43 / 38 / 32
2250 A	1125 A	1.4x	50%	15 Minutes	15 Minutes	61 / 53 / 45
3200 A	1600 A	2x	25%	5 Minutes	15 Minutes	86 / 75 / 65
4800 A	2400 A	3x	10%	2.5 Minutes	20 Minutes	129 / 112 / 97
6400 A	3200 A	4x	6%	75 Seconds	20 Minutes	173 / 150 / 129
8000 A	4000 A	5x	4%	4 Seconds	2 Minutes	216 / 187 / 161
11200 A	5600 A	7x	2%	2 Seconds	2 Minutes	303 / 262 / 226
16000 A	8000 A	10x	1%	0.6 Second	1 Minute	433 / 375 / 323
25000 A **	12500 A **	15x	0.5%	0.1 Seconds	1 Minute	555 **

\*\*Maximum output current possible into short circuit with very low source impedance

#### Additional Equipment Required

Requires a complete PI-800 GEN2 (including MAC-21) for operation  
See separate data sheet for specifications

## SECTION II

### DETAILED DESCRIPTION

#### THEORY OF OPERATION

##### High Current Test Sets

High current test sets generally consist of the following:

1. One or more coarse taps accomplished by:
  - (a) A tapped autotransformer providing several equal steps of voltage or
  - (b) A multi-section output transformer
2. A continuously variable vernier adjustment between coarse taps by means of:
  - (a) A variable autotransformer and boost transformer, or
  - (b) A variable autotransformer connected to a section of the output transformer.
3. An output transformer with one or more isolated low voltage, high current secondary.
4. Power control circuitry consisting of switches, relays, protective devices, etc.
5. Current measurement circuitry consisting of sensors, current meter, and timer.

In general, a primary voltage is selected by means of a combination of coarse tap and vernier adjustment. This voltage is stepped down by the output transformer to provide the desired current into the load impedance.

##### PI-800 GEN2 Main Unit Circuitry

Main power is applied to the PI-800 GEN2 by means of standard high current plug and socket connectors, which are supplied for the customer to connect to the power source with appropriate flexible leads. A ground terminal with wing nut and washers is provided for a solid ground connection.

Primary protection is provided by high capacity 60 ampere input fuses **F1** and **F2**. After that, the control section is protected by smaller 2 ampere fuses **F3** and **F4**, and the power section is isolated by means of a high current contactor **K1**.

The input is connected, through voltage selector switch **S1**, to a wide range switching power supply to provide 12 VDC to the control circuitry and fans. Input voltage is sensed by voltage relay **K8**, and when the primary voltage is Correct this relay energizes. The Input Select Error indicator **DS2** lights if it senses an

incorrect connection.

The input voltage selector switch **S1** sets the primary windings of transformer. When the control power switch **S3** on the front panel is pressed, and all voltage interlocks are OK, relay **K4** is energized, which provides 120 VAC control power to the entire test set.

If all power interlocks are OK, a second set of contacts on **S3** activate the main contactor **K1**. This provides high current power to the test set output circuitry through the SCR controller.

The dual vernier autotransformer **T1** and **T2**, and output transformers **T5** and **T6**, are connected to input voltage selector switch **S1**. This allows for connection in series for 240 VAC, and parallel for 120 VAC. Verniers **T1** and **T2** are connected through paralleling transformer **T3** and the **POD**, directly to the primaries of output transformer **T4**, so that clockwise rotation produces an output voltage of about 0-0.84 VAC for each secondary turn. Relays **K2** and **K3**, energized by tap switch **S2**, connect the primary windings of **T5** and **T6** to main power, for fixed outputs of 0, 0.78, or 1.56 VAC for taps 1, 2 and 3, for a maximum of 2.40 VAC per turn. The outputs may be connected in series for 4.8 and 9.6 VAC.

Output current is detected by means of air core CTs **L1-L4** on each main bus. Switch **S7** on the calibration board is set to correspond to the output configuration of 400, 800, or 1600 amps. Calibration of each mode is accomplished with potentiometers on the calibration board assembly under the output face plate.

The output section is energized when a signal is applied to the trigger board of the SCR controller. The initial phase angle is determined by a zero-crossing detector in the trigger PCB, and a delay which is normally preset to **70 degrees**. The output of the SCR is distributed to **T1** and **T2**, and output transformers **T5** and **T6** through the tap relays. This voltage is also supplied on connector **J6** for the *PI-Aux* Boost Unit.

The Vernier autotransformer is adjusted manually by means of a knob. Increasing output is clockwise for all taps.

When **T1** and **T2** are energized, neon lamp **DS14** on the rear panel and lamp **DS2** on the front panel are Lit. This provides a visual indication from the front and rear when output is on.

Thermistor **TH1** senses the temperature of the output bus. This normally has a resistance of 10 K ohms at room temperature, and lower values as the temperature increases. This value is read by the **POD** and used to compute and display the virtual temperature of the test set on LEDs **DS10-DS12**.

The output of the adjustable Vernier assembly in the *PI-800 GEN2* is monitored directly by means of the Programmable Overload Monitor (**POD**). The overall system status is displayed on LEDs **DS10-DS12**, and the peak output current is displayed on LEDs **DS7-DS9**. An interlock relay shuts down the output of the test set if abnormal conditions are detected. More details are in the appendix. The **POD** interlock may be defeated by holding switch **S5** on.

### PI-Aux Boost Unit Circuitry

The *PI-Aux* Boost Unit connects to the *PI-800 GEN2* to form the *PI-1600 GEN2*. SCR controlled voltage from the *PI-800 GEN2* is distributed to the four tap relays **K1-K4**, which provide power to the primaries of **T1-T4** when energized. Output ON indicators **DS1** and **DS2** light when voltage is applied to the main input. Fans **B1** and **B2** are powered from the 12VDC supply.

## MAJOR PARTS IDENTIFICATION AND OPERATION

### PI-800 GEN2 Front Panel

**Input Jacks J3 and J4:** These 50 ampere male jacks are to be connected to main power.

**Ground Terminal J2:** This ¼" steel lug with wingnut is used to connect the frame of the test set to a solid earth ground.

**Input Voltage Lamp DS1:** This amber neon lamp glows whenever voltage above about 90 volts is present on the input jacks.

**Input Selector Switch S1:** This three-position switch is used to select the proper input configuration for the mains voltage on which the test set is to be used. The center OFF position disconnects the test set from the input voltage, although the Input Voltage lamp still indicates the presence of voltage.

**Control Power ON switch S3:** This green switch turns on 120 VAC control power to the test set, and its green lamp lights when ON. It also resets the output interlock and energizes the interlock contactor **K1** if all interlocks are clear.

**Interlock/Stop switch S4:** This red switch turns off the main output of the test set by deenergizing contactor **K1**. Its lamp lights when there is an interlock condition.

**Output ON lamp DS5:** This yellow lamp turns on when test set output is ON.

**Interlock Bypass Switch S5:** This yellow switch, when held ON, bypasses the POD interlock. This should be used only if there is a defect in the POD circuitry. Damage to the test set may result if abused.

**Tap Selector Switch S2:** This seven-position switch is used to select the desired coarse output tap. Positions 4-7 are used only for the *PI-1600 GEN2*. Never change output tap while output is on. The output is deenergized between taps, but damage to the test set may result if output is not turned off before changing taps.

**System Status LEDs DS10-DS12:** These multicolor LEDs indicate approximate internal temperature of the test set. The Green LED indicates normal temperature. A Green + Yellow LED indicates slight heating, and a Yellow LED indicates

## Electrical Test Instruments PI-800 GEN2 and PI-1600 GEN2

moderate heating. A Yellow+ Red LED indicates significant heating, and heavy testing should be postponed until unit cools to Yellow. A Red LED indicates severe overheating, and the unit will soon trip the interlock. Allow the test set to cool to Red + Yellow range before testing. Temperature indication is a combination of actual bus temperature and “virtual temperature” as determined by duty cycle usage. The virtual temperature will be reset if test set power is turned off, but actual temperature will be indicated.

**Output LEDs DS7-DS9:** These multicolor LEDs indicate approximate overload current of the test set. The Green LED indicates current up to about 1x, where the test set may be used continuously. Green + Yellow indicates about 2x, and Yellow indicates 3x. The test set may be used for up to about 5 minutes ON time at 3x, followed by at least 5 minutes cooling. Yellow + Red is about 4-7x, and Red is about 8-10x. These overloads may be sustained for only about 5 seconds or less. Red + Yellow + Green indicates a severe overload which will trip the interlock within 0.5 seconds. The output LEDs hold their reading for several seconds. If interlock is tripped, the Red LED will flash until clear.

**Vernier Adjust Knob:** This knob adjusts the output Vernier. Clockwise rotation increases output in all tap positions.

**Aux Unit Power Jack J6:** This female three position jack is used to supply main power to the *PI-AUX* Booster Unit for the *PI-1600 GEN2* configuration. Voltage may be present on this connector anytime the interlock contactor is closed. A safety cover or other means should be used to prevent inadvertent contact with energized conductors when the *PI-AUX* unit is not connected.

**Aux Unit Control Jack J1:** This female 14 position jack is used to supply 120 VAC control signals and 12 VDC power to the *PI-AUX* Booster Unit for the *PI-1600 GEN2* configuration. Voltage may be present on this connector anytime the interlock contactor is closed. A safety cover or other means should be used to prevent inadvertent contact with energized conductors when the *PI-AUX* unit is not connected.





# MEMORY AMMETER CONTROLLER MAC-21

## INSTRUCTION MANUAL

Firmware Version 3.06 and above

Electrical Test Instruments, LLC  
8430 Spires Way, Suite A  
Frederick, MD 21701

[www.etiprecision.com](http://www.etiprecision.com)

p (410) 857-1880  
f (410) 857-1387

## MAC-21 Specifications

### INPUT POWER:

120 VAC, SINGLE PHASE  
50/60 HZ, 20 VA Max

### CURRENT RANGES:

0-1,000 / 5,000 / 25,000 / 100,000 Amperes

### CURRENT ACCURACY:

+/- 0.5% Reading + 0.5% Range + 1 Digit (Continuous)  
+/- 1.0% Reading + 1.0% Range + 1 Digit (Pulse > 0.01 sec)

### TIMER RANGES:

0-9.999 / 0-99.99 / 0-999.9 / 0-9999 Seconds  
0-999.9 / 0-9999 Cycles

### TIMER ACCURACY:

+/- 0.5% of reading +/- 1 count

### DIMENSIONS AND NET WEIGHT

Height: 7.0 in. (178 mm)  
Width: 19.0 in. (483 mm)  
Depth: 2.0 in. (51 mm)  
Weight: 3.7 lb. (1.68 kg)

### STANDARD ACCESSORIES

Remote Initiate cable	1	S-B143
Contact Leads	1 pair	S-A108

## MAJOR PARTS IDENTIFICATION AND OPERATION

### MAC-21 Control Panel

**TIME DISPLAY:** This 4-digit LED display normally indicates the elapsed time of a current pulse. In SECONDS mode, it displays time up to 9.999 seconds, then auto ranges to 99.99 seconds, 999.9 seconds, and 9999 seconds. In CYCLES mode, it reads time (based on 60 Hz), up to 999.9 cycles, then auto ranges to 9999 cycles. If time exceeds maximum display capacity (10,000 seconds or 10,000 cycles), the display will read "OVER". In PRESET mode, the display indicates the maximum time of initiation (ON time), in either cycles or seconds. A reading of zero disables the PRESET function and allows any time.

**CURRENT DISPLAY:** This 4-digit LED display indicates the output current. In CONTINUOUS mode, as well as in MEMORY mode before and during a test, the display indicates true-RMS output current in real time. After completion of a test, in MEMORY mode, the display shows the true-RMS value as computed over the entire length of the pulse. This mode is indicated by a flashing LED on the MEMORY key. If a reading exceeds the maximum value for the selected range, the display will read "OVER".

This display is also used. When the time base is in SECONDS mode, press the STOP key to display the last average RMS value displayed in CONTINUOUS mode. This is useful for pickup tests. It may not be accurate for times less than 1 second.

**INITIATE key:** This key is used to turn ON the output of the test set. The LED in the key indicates that the MAC-21 is attempting to turn the output ON, but other conditions (such as interlocks) could keep the output from actually turning on. In MOMENTARY mode, the key must be held to keep output current on. In MAINTAIN mode, once current is detected, the output will stay on until the breaker trips, or the STOP or RESET button are pressed. The MAC-21 must be RESET in order to initiate output, and in N.C. or N.O. contact modes, the contact status (continuity) must indicate that the breaker is closed. If the output on time exceeded the PRESET time, as indicated by flashing of the PRESET key LED, the INITIATE key will automatically reset the MAC-21 and turn the output on.

**STOP key:** This key is used to turn the output of the test set OFF. Its LED indicates that output is not being turned on by the MAC-21, but other conditions could cause output voltage to be ON. Use of this key is usually necessary only when in MAINTAIN mode, and it is necessary to abort the test before the breaker trips. **NOTE:** It is important to realize that the interlock system of the circuit breaker test set may also turn the output off, but it will turn back ON when the interlock condition is cleared (in N.O. and N.C. modes only).

**RESET key:** This key reset the displays on the MAC-21, and arms the pulse reading system. The LED on the key indicates that the system is reset and armed. RESET also takes the unit out of PRESET ADJUST mode.

**MAINTAIN key:** This key toggle the MAINTAIN mode for initiation; its LED indicates

## Electrical Test Instruments PI-800 GEN2 and PI-1600 GEN2

that this mode is enabled. When in MAINTAIN mode, the INITIATE key need only be pressed briefly to turn output on. MAINTAIN must be set in order to read pulse current when output is initiated by means other than the MAC-21.

For test sets with motorized vernier, the MAINTAIN key may be pressed while output is ON to provide automatic current hold. The LED in the MAINTAIN key will blink while this mode is set, and the vernier motor will be activated whenever the current varies more than 5 amperes from the value displayed when the key was pressed. The key may be pressed again to return to normal mode. STOP or RESET will also discontinue current hold.

**N.O. key:** This key is used to set the Normally Open contacts mode. In this mode, lack of continuity on the CONTACTS binding posts indicates that the protective device under test is in its normal (non-tripped) mode, and ready to accept current. In N.O. mode, after the INITIATE key is pressed, the timer starts when current (about 3% of range) is detected. The timer stops when the STOP key is pressed, or continuity is sensed at the CONTACTS binding posts. Timing accuracy in this mode is typically +/- 0.01 seconds.

**N.C. key:** This key is used to set the Normally Closed contacts mode. In this mode, continuity on the CONTACTS binding posts indicates that the protective device under test is in its normal (non-tripped) mode, and ready to accept current. This mode may be used for testing multi-pole breakers by connecting the CONTACTS binding posts to an unused pole. In N.C. mode, the timer starts as soon as current (about 3% of range) is detected after the INITIATE key is pressed and stops when the STOP key is pressed or a break in continuity is sensed at the CONTACTS binding posts. Timing accuracy in this mode is typically +/- 0.01 seconds.

**C.L. key combination:** When the N.O. and N.C. keys are pressed simultaneously, both LEDs light, indicating C.L. mode (Current Latch). This is the normal power-up default mode for the test set, and is recommended for all tests, unless there is a good reason for using contacts to sense trip. In this mode, current is continuously sampled, and when it exceeds approximately 10% of the current range value, the timer starts, and calculation of pulse current begins. When current stops (or drops below a dynamically determined threshold value), the timer stops running, and the final value for pulse current is calculated and displayed. If the output was initiated by the MAC-21, it is turned OFF. **NOTE:** in C.L. mode only, the contacts jacks may be used for remote initiation (see below).

**PRESET key:** This key toggle the PRESET ADJUST mode, indicated by illumination of its LED. When PRESET ADJUST is active, the adjacent SECONDS and CYCLES keys respectively lower and raise the preset time in seconds or cycles, depending on the time base that was selected. Both keys may be pressed simultaneously to reset the time limit to zero, which disables the time limit function. When not in PRESET mode, the LED will flash if the displayed time exceeds the preset limit.

**SECONDS key:** This key normally selects the SECONDS time base. If the PRESET mode is selected, this key is used to LOWER the preset time limit by decrements of 1.000 second (5.000 seconds above 10.00) with the SECONDS time base, or 1.0 cycles with the CYCLES time base. If it is held, the reading will decrease at a rate of about 5 intervals per second. If a preset time limit was set in SECONDS mode, the output will

## Electrical Test Instruments PI-800 GEN2 and PI-1600 GEN2

be turned off within 200 milliseconds of the limit. SECONDS or CYCLES time base may be selected at any time before, during, or after a test.

**CYCLES key:** This key normally selects the CYCLES time base. If the PRESET mode is selected, this key is used to RAISE the preset time limit by increments of 1.000 seconds (5.000 seconds above 10.00) with the SECONDS time base, or 1.0 cycles with the CYCLES time base. If it is held, the reading will increase at a rate of about 5 intervals per second. If a preset time limit was set in CYCLES mode, the output will be turned off within several milliseconds after the limit has been reached. SECONDS or CYCLES time base may be selected at any time before, during, or after a test.

**MEMORY key:** This key toggle the MEMORY mode, indicated by illumination of its LED. When in CONTINUOUS mode (LED off), the current display always reads the real-time continuous output current of the test set. In MEMORY mode (LED on), the current display will read the continuous output current until the test is complete. At this time, the LED will flash, and the display will read the computed true-RMS value of the entire current pulse for the duration indicated on the TIME display. This key may be pressed at any time before, during, or after the test, to toggle between the two modes.

As described above, pressing the STOP key provides access to display of peak RMS and last average RMS current.

**1000 A range key:** This key selects the 1000 ampere range, which provides best accuracy of readings up to about 1000 amperes. Nominal currents close to this limit, when applied to the device under test, will sometimes cause higher peak currents, causing the display to read "OVER", indicating an overrange condition. If this happens, select the next higher range. Pressing any range switch will also RESET the MAC-21.

**5 KA range key:** This key selects the 5.000 KA range, for output currents up to about 5,000 amperes. See above for information common to all ranges.

**25 KA range key:** This key selects the 25.00 KA range, for output currents up to about 25,000 amperes. See above for information common to all ranges.

**100 KA range key:** This key selects the 100.0 KA range, for output currents up to about 100,000 amperes. See above for information common to all ranges.

**CONTINUITY lamp:** This LED lights when continuity is detected at the CONTACTS binding posts in N.O. and N.C. modes. The beeper will also sound whenever contacts change state.

**CONTACTS/REMOTE jacks:** These jacks provide a low-power AC signal which detects continuity in N.O. and N.C. modes, or is used with a pushbutton cord switch for remote initiate function (see below). A resistance of about 200 ohms or less will be interpreted as continuity. Although the signal is low power and transformer isolated, it is good practice to avoid touching any conductive surface connected to these terminals. **CAUTION: NEVER CONNECT THESE TERMINALS TO ANY LIVE CIRCUIT!**

**REMOTE INITIATE:** In C.L. mode only, the CONTACTS jacks provide a remote initiate function. For safety reasons, this function is disabled in MAINTAIN mode, unless a

## Electrical Test Instruments PI-800 GEN2 and PI-1600 GEN2

preset value is set in CYCLES time base.

**SERIAL port:** This standard serial port may be connected to a printer, computer, or other device to print or store time and current values of test results in ASCII format. It is set for 9600 baud, 8 bits, 1 stop bit, no parity, no flow control. This information is sent at the end of each test, or by pressing the Stop and Reset keys.

**Report Generator Software Option:** we also offer a software package for a Windows based computer that takes the data from the serial port and inserts time and current values into an excel document. Must have Microsoft office installed for this software to function properly. This can be custom tailored to your excel document or use the generic document that is provided with the software

## MAC-21 Internal Parts

**INPUT CONNECTOR:** This connector, located on the upper rear corner of the MAC-21, provides 120 VAC control power, and connects to the air core CT (current sensor), and initiate circuitry of the test set and is designed to facilitate removal of the MAC-21 for service or shipment. Additional pins are used to provide isolated logic level control for motorized vernier raise and lower for the current hold feature.

Figure II-2: MAC-21 Front Panel

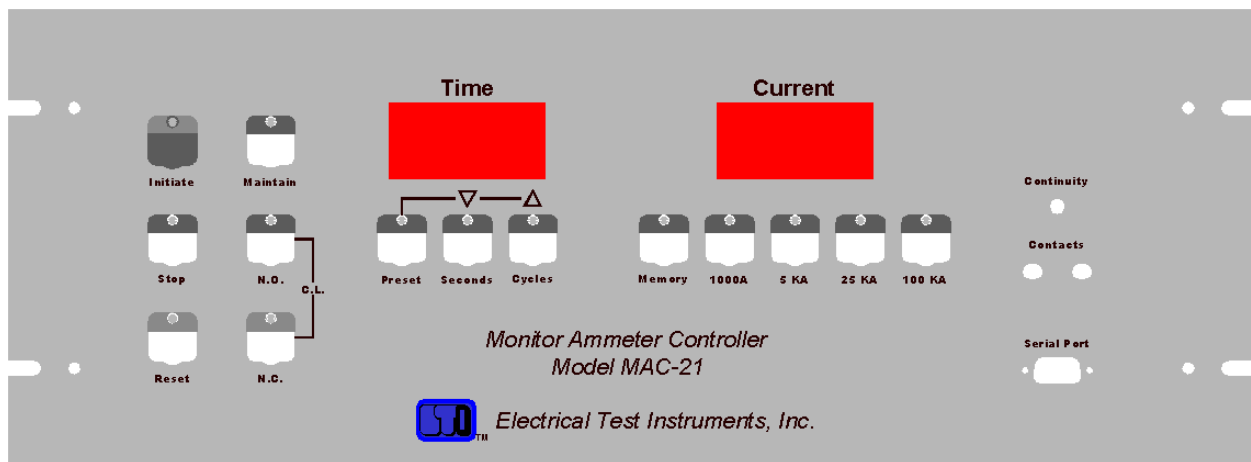

## SERVICE INFORMATION AND DOCUMENTATION

### MAINTENANCE AND CALIBRATION OF THE MAC-21

The MAC-21 is manufactured using solid state components that should not require extensive maintenance. However, the accuracy of the MAC-21 is critical to the testing of circuit breakers and is dependent upon the output of an air-core current sensing coil, which could change due to movement caused by shock or vibration encountered in transporting the test set. Other factors which may affect calibration are contact resistance in the control cable, unusual magnetic fields, insulation leakage, and aging of electronic components in the MAC-21. Therefore, proper operation and calibration should be checked at regular intervals and adjusted if proper equipment is available.

Field calibration of the MAC-21 may be performed as follows:

1. Obtain a current measuring calibration standard capable of reading TRUE-RMS current up to at least 1000 Amperes to an accuracy of at least 0.25%. This may consist of a shunt or current transformer, in conjunction with a digital multimeter or laboratory grade AC ammeter.
2. Set up the breaker test set for normal breaker testing. If adjustments are anticipated, remove the MAC-21 from the test set.
3. Connect the calibration standard to the desired output tap. If cables are used, it is recommended that they be twisted so as to minimize radiation and pickup of stray magnetic fields.
4. Apply power to test set and allow at least one minute for circuits to stabilize.
5. Check ammeter zero in all ranges. If reading on current meter is greater than 1% of range, internal zero adjustment may be required.
6. Set MAC-21 Range to 1000 A and adjust output of breaker test set to exactly 800 Amperes. If Coarse Tap is 1, and Output Control Vernier is less than 50%, additional resistance must be added to output circuit. This is important, because waveform distortion is more prevalent at lower levels.
7. If the MAC-21 reading differs from the standard by more than rated accuracy, adjust the gain potentiometer on the analog board for proper reading. If an error of more than 5% is noted, and unit has been in service, the accuracy and validity of previous tests may be questionable; otherwise, there may be a problem in the test setup.



## Electrical Test Instruments PI-800 GEN2 and PI-1600 GEN2

8. Check calibration at 200, 400, 600, and 1000 Amperes.
9. Adjust the current to zero, and press RESET key.
10. Raise the current slowly, until the timer begins to run. This is the Current Latch Threshold, which should be about 10% of range.
11. Set the current at 50% of full scale (500 A) and stop the current.
12. Set the MAC-21 to MEMORY mode and press the RESET Switch.
13. Initiate a fast-momentary pulse of no more than 6 cycles (0.1 Sec) duration. The meter should read the same value, within 1% of reading + 1% of range, that was set in step 11 above.
14. Check pulse reading operation in this manner for currents of 200, 400, 600, and 1000 Amperes, and varying duration.
15. Set Timer Time base to SECONDS. Press Master Reset Switch. Set N.O. mode. Using a stopwatch, initiate for exactly ninety (90) seconds. Timer should read 90.00 Seconds, +/- 0.01 Seconds. (Note: actual reading may vary because of inability to control and measure pulse length.)
16. If everything checks out, the MAC-21 can be assumed to be in calibration, and no other adjustments are required.

### PARTS LIST (MAC-21):

The overall schematic is on the following pages. The parts list is provided below. Please refer to both when ordering replacement parts.

ITEM	QTY	DESCRIPTION	Part Number
1	1	MAC-21 Contact/LED Harness	S-B369
2	1	MAC-21 Rear Panel Harness	S-B368
3	1	MAC-21 Metal Cage	M-D464
4	1	MAC-21 Main PCB	M-C492
5	1	MAC-21 Membrane Switch Panel	M-D462
6	6	LOCKWASHER, INT TOOTH #4	M-A116
7	6	SCREW, PH, 4-40x1/4	M-A118
8	2	HANDLES, BRASS, NICKEL PLT, 4"	M-C103
9	4	SCREW, RH, 10-32x1/2	M-A158
10	4	FLATWASHER, #10	M-A159
11	4	LOCKWASHER #10	M-A160
12	4	SCREW, PH, 10-32X3/4	M-A191
13	4	NYLON WASHERS #10	M-A155
14	2	JACKSCREW, .312, W/HARDWARE	M-A125
15	4	SCREW, PH, 6-32x1/4	M-A139
16	1	COMMUNICATION CABLE	S-A106

**Connections (MAC-21):**

## SECTION IV

### OPERATING INSTRUCTIONS

#### PRE-TEST INSTALLATION AND SET-UP

1. The following components of the test set should be available and in good condition:
  - a) *PI-800 GEN2* Main Unit
  - b) *PI-AUX* Booster Unit (If required for *PI-1600 GEN2*)
  - c) *MAC-21* Remote
  - d) Stab set or cables to match breaker to be tested
  - e) Input power plugs and cables
  - f) Input ground lead
  - g) Contact lead set (If applicable)
  - h) Remote initiate cable (optional)
2. Additional requirements for testing are as follows:
  - a) Breakers to be tested
  - b) Manufacturers' curve data
  - c) Test log and/or report forms (See examples at end of section)
  - d) Basic hand tools (wrench, screwdriver, etc.)
  - e) Safety equipment (safety glasses, gloves, etc.)
  - f) Reliable and sufficient power source
  - g) Clean, spacious, and well-lit work area.
3. Identify which Unit you have Option A or Option B. This is on the Unit with the serial number or look at input voltage switch.
  - Option A Input Voltage Switch Labeled 120V, 208V-240V
  - Option B Input Voltage Switch Labeled 208V, 240V, 277V
4. The voltage selector must be set to match input voltage.
  - Option A requires 120VAC or 208-240VAC
  - Option B requires 208VAC, 240VAC or 277VAC
5. Calculate KVA requirements for the source per manufacturer's manual.
6. Remove lids from front and rear of all units.

## Electrical Test Instruments PI-800 GEN2 and PI-1600 GEN2

7. For *PI-1600 GEN2*, place *PI-800 GEN2* on top of *PI-AUX* Boost Unit, plug power and control cables into jacks on *PI-800 GEN2*. Connect inner output terminals with M-D175 connection bars per diagram. Verify proper vertical alignment before tightening and secure latches.
8. Attach appropriate bus interconnectors or cables for desired output current mode per diagram. Make sure all connection surfaces are clean and all bolts are tight.
9. **Important!** Set output mode switch to proper position. See diagram.
10. Connect the *PI-800 GEN2* to a good earth ground with at least #10 AWG wire.
11. Place *MAC-21* on top of *PI-800 GEN2* and connect to jack on rear.
12. If possible, TURN OFF power at source.
13. Connect power source to input, using connectors supplied.
14. Turn on power at source, if turned off in step 11 above.
15. Input Voltage lamp should light, and fans should run. Input selector error LED should light if input voltage is incorrect.
16. Press Control Power switch. Green lamp should light, main contactor should pull in, and *MAC-21* should power up.
17. Connect breaker under test to appropriate output tap, using stabs or cables and series bar as required.
18. Make sure that breaker is CLOSED.
19. Follow Step-by-Step procedures below, as required, for testing.
20. When tests are completed, press INTERLOCK switch to turn Main Power OFF.
21. Turn input switch to OFF to turn Control Power OFF.
22. Turn off supply power, if possible, and disconnect input power cables.
23. Remove ground cables from *PI-800 GEN2* to earth ground.
24. Remove output buswork, interconnecting cables, etc., and replace lids on all units for safe transport.

# Electrical Test Instruments PI-800 GEN2 and PI-1600 GEN2

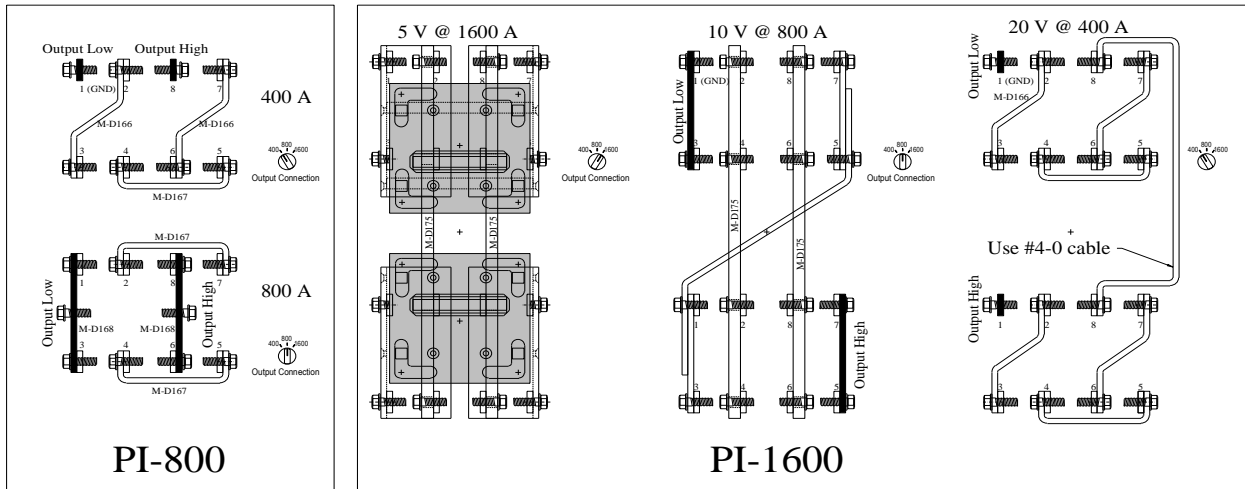

## Output Connections

10/06/03 - PES

## **BASIC GUIDELINES AND SUGGESTIONS**

1. Best timing and current accuracy will be obtained with the MAC-21 in current latch (C.L.) mode.
2. Current Latch modes are preferred for most testing purposes. Exceptions are:
  - a) Non-series-connected devices such as motor overload relays or shunt-trip breakers.
  - b) Ratioing of current transformers.
  - c) Heat runs of cables, buswork, etc. (Connect contacts to thermostat).
3. If Contacts Mode is selected, use caution when connecting continuity sensing cables. Although the voltage and current are minimal, under some conditions it could cause electrical shock. ALWAYS connect one clip at a time, and NEVER rest the other hand on any current-carrying parts of the breaker while the test set is powered up.
4. Always choose an ammeter range that allows the test current to be read in the area from 20% to 80% of the maximum. This provides greatest accuracy of readings, least chance of overrange, and optimum current latch operation.
5. To obtain maximum output current from the test set, especially when using output cables, it is important to minimize both input and output impedance. This can be accomplished by using the largest cable size possible, or using multiple cables in parallel, to reduce resistance, and by keeping cables close together by tying or twisting, to reduce inductance.
6. For all breaker test sets, much better output current waveform and stability can be achieved when the controls of the test set are in their higher positions. To test smaller breakers, it is helpful to introduce additional output impedance, by using some length of adequate, but lighter gauge, wire to connect the breaker to the output connections. When using tap 1, the vernier control should always be at least at 30% to produce desired test current.

## **DUTY CYCLE RATINGS**

Overload capacity is based on cumulative heating of transformers and bus conductors. Heating is a function of the power dissipated, which is proportional to the square of the current. The continuous current rating is based on that which will cause a temperature rise which is within the safe limits, usually defined by the temperature rating of the winding insulation. Transformers used for testing can usually be used at a 50% duty cycle, which allows 1.414

## Electrical Test Instruments PI-800 GEN2 and PI-1600 GEN2

times the true continuous current for a maximum of 15 to 30 minutes, followed by an equal amount of time for cooling. This is generally a reasonable duty cycle for circuit breaker testing.

A circuit breaker rated at the true continuous rating of a test set is usually tested for long time trip at 3x, where trip times of 30-120 seconds are common. If three poles are tested in rapid succession, a maximum ON time of 360 seconds, or 6 minutes, would be required. The duty cycle at 3x is 1/9, or about 11%, so an OFF-time of 2912 seconds, or 48 minutes, would be required for complete cooling. Testing does not usually run to the maximum, so if breaker trip times were actually 60 seconds, the test set would cool completely in 24 minutes. It would also be possible to test another breaker with similar timing immediately, without waiting for the test set to cool.

Short time and instantaneous testing usually have much less effect on overall heating. For a 6x short time test, the duty cycle is 1/36, or about 2.8%. Trip time is usually 0.5 seconds, so complete cooling would occur in about 18 seconds. Thus, successive tests may usually be run without concern for overheating. For a 10x instantaneous test, the duty cycle is 1/100, or 1%, but trip time is usually less than 0.1 seconds, so complete cooling would occur in 10 seconds.

The output specifications of the test set take into account that current above about 4x will be for short time and instantaneous tests, and maximum ON times are reduced accordingly. This also reduces the minimum OFF time. Remember that the minimum OFF time is based on the premise that the output was ON for the maximum time. If the output was ON for only 1/10 the maximum ON time, the minimum OFF time to adhere to duty cycle limits is also 1/10. Another way to look at it is that 10 successive tests at 1/10 maximum ON time could be performed, and then the minimum OFF time would be required for complete cooling.

It is also not necessary to wait until the test set has cooled completely in order to perform another test. However, if a test set that has heated to its maximum has only cooled for 1/4 of the specified time, it will only be able to produce on times of about 1/4 of the maximums allowed when fully cooled.

The Programmable Overload Device (POD) takes all of these factors into account, so you do not need to worry about making complex calculations or recording ON and OFF times. The virtual temperature indicator (System Status) shows the thermal condition of the test set and will indicate when it is safe to proceed with another test. It is generally safe to perform short time and instantaneous tests if there is no severe overheating, and long-time tests may be performed if the test set has cooled about halfway. These guidelines should allow mostly unrestricted testing in all but the most demanding situations, and then will indicate when it is safe to proceed without worrying about an

overload trip or test set damage.

It is also important to note that a severely overheated test set may not produce as much instantaneous current as it will when cool, due to higher resistance of copper buswork when hot. Copper has about 50% higher resistance at 100 degrees C than it does at 25 degrees C. For this reason, it may be best to perform instantaneous tests before heating the test set and buswork or cables with long time tests.

## SINGLE POLE MOLDED CASE CIRCUIT BREAKERS

### Timing Test

1. Consult breaker manufacturer's literature to determine any necessary precautions and expected test results. A test current of three times the rating of the breaker should be used for this test.
2. Follow steps 1 through 17 in pre-test installation and setup, as required, to set up the breaker test set.
3. Setup MAC-21 for C.L. Maint (MAINTAIN on).
4. Set MAC-21 RANGE to lowest range that is greater than desired test current.
5. Set TIMEBASE to CYCLES.
6. Press PRESET key. Adjust preset time to 5.0 cycles. This value may be set higher or lower, depending on trip characteristics of breaker.
7. Press PRESET again to return to normal mode.
8. Select MEMORY mode.
9. Repeatedly jog the INITIATE button, while adjusting the OUTPUT CONTROL higher, until the desired test current is read on the ammeter. If insufficient current is obtained at maximum position of the vernier, set the OUTPUT TAP control to the next higher tap, return the vernier to zero, and continue.
10. Press RESET button.
11. Set TIMEBASE to SECONDS.
12. Select MAINTAIN mode.
13. Press and release INITIATE key; OUTPUT ON light should glow, timer should run, and current display should read desired output current.
14. While test is running, observe current reading. If necessary, adjust to correct value by using vernier control, or press MAINTAIN key for current hold.
15. When breaker trips, the test set output should de-energize, timer should stop, and OUTPUT ON light should turn off.



## Electrical Test Instruments PI-800 GEN2 and PI-1600 GEN2

16. Read and record trip current and trip time. Compare to manufacturer's time/current curve.
17. If test is to be repeated, make sure that breaker cools completely.
18. Shut down test set, disconnect breaker, and prepare for subsequent testing or relocation according to steps 19 through 23 in pre-test installation and setup outlined above.

### Pick-Up of Instantaneous Element

1. Consult breaker manufacturer's literature to determine any necessary precautions and expected test results. Check the breaker's instantaneous setting. Pickup should occur at about that current.
2. Follow steps 1 through 17 in pre-test installation and setup, as required, to set up the breaker test set.
3. Setup MAC-21 for C.L. Maint (MAINTAIN on).
4. Set MAC-21 RANGE to lowest range that is greater than desired test current.
5. Set TIMEBASE to CYCLES.
6. Press PRESET key. Adjust preset time to 5.0 cycles. This value may be set higher or lower, depending on trip characteristics of breaker.
7. Press PRESET again to return to normal mode.
8. Select MEMORY mode.
9. Repeatedly jog the INITIATE button, while adjusting the OUTPUT CONTROL higher, until the circuit breaker trips instantaneously. This is the approximate pickup point. If insufficient current is obtained at maximum position of the vernier, set the OUTPUT TAP control to the next higher tap, return the vernier to zero, and continue.
10. Close breaker under test.
11. By repeating the test, determine the MINIMUM SETTING of the OUTPUT CONTROL, at which the breaker under test opens immediately, whenever the INITIATE button is depressed.
12. Read and record ammeter reading as instantaneous pick-up of the breaker.
13. Shut down test set, disconnect breaker, and prepare for subsequent testing or relocation according to steps 19 through 23 in pre-test installation and setup outlined above.

### **Instantaneous Trip Time Test**

1. Perform Instantaneous Pickup Test as outlined above.
2. Adjust controls to obtain current above pickup, at approximate desired multiple of rating.
3. Close breaker under test.
4. Press the INITIATE button. Breaker should trip instantaneously.
5. Read and record timer and ammeter readings as instantaneous trip time and current.
6. Shut down test set, disconnect breaker, and prepare for subsequent testing or relocation according to steps 19 through 23 in pre-test installation and setup outlined above.

## **MULTI-POLE MOLDED CASE CIRCUIT BREAKERS**

### **Timing Test**

1. Consult breaker manufacturer's literature to determine any necessary precautions and expected test results. A test current of three times the rating of the breaker should be used for this test.
2. Follow steps 1 through 17 in pre-test installation and setup, as required, to set up the breaker test set.
3. Connect appropriate output tap to one pole of breaker under test.
4. Setup MAC-21 for C.L. Maint (MAINTAIN on).
5. Set MAC-21 RANGE to lowest range that is greater than desired test current.
6. Set TIMEBASE to CYCLES.
7. Press PRESET key. Adjust preset time to 5.0 cycles. This value may be set higher or lower, depending on trip characteristics of breaker.
8. Press PRESET again to return to normal mode.
9. Select MEMORY mode.
10. Repeatedly jog the INITIATE button, while adjusting the OUTPUT CONTROL higher, until the desired test current is read on the ammeter. If insufficient current is obtained at maximum position of the vernier, set the OUTPUT TAP control to the next higher tap, return the vernier to zero, and continue.
11. Press RESET button.
12. Set TIMEBASE to SECONDS.
13. Select MAINTAIN mode.

## Electrical Test Instruments PI-800 GEN2 and PI-1600 GEN2

14. If desired, N.C. mode may be used; connect contacts leads to an unused pole of the breaker.
15. Press and release INITIATE key; OUTPUT ON light should glow, timer should run, and current display should read desired output current.
16. While test is running, observe current reading. If necessary, adjust to correct value by using vernier control.
17. When breaker trips, the test set output should de-energize, timer should stop, and OUTPUT ON light should turn off.
18. Read and record trip current and trip time. Compare to manufacturer's time/current curve.
19. Repeat above tests for other poles of the breaker. Allow time for breaker to cool. Note: it is acceptable if all poles of the breaker trip within +/- 15% of the manufacturer's time range for the value of test current chosen. All poles of the breaker need not trip in exactly the same amount of time.
20. Shut down test set, disconnect breaker, and prepare for subsequent testing or relocation according to steps 19 through 23 in pre-test installation and setup outlined above.

### Pick-Up of Instantaneous Element

1. Consult manufacturer's literature to determine any necessary precautions and expected test results. Check the breaker's instantaneous setting. Pickup should occur at about that current.
2. Follow steps 1 through 17 in pre-test installation and setup, as required, to set up the breaker test set.
3. Setup MAC-21 for C.L. MOM.
4. Set MAC-21 RANGE to lowest range that is greater than desired test current.
5. Set TIMEBASE to CYCLES.
6. Press PRESET key. Adjust preset time to 5.0 cycles. This value may be set higher or lower, depending on trip characteristics of breaker.
7. Press PRESET again to return to normal mode.
8. Select MEMORY mode.
9. Repeatedly jog the INITIATE button, while adjusting the OUTPUT CONTROL higher, until the circuit breaker trips instantaneously. This is the approximate pickup point. If insufficient current is obtained at maximum position of the vernier, set the OUTPUT TAP control to the next higher tap, return the vernier to zero, and continue.
10. Close breaker under test.

## Electrical Test Instruments PI-800 GEN2 and PI-1600 GEN2

11. By repeating the test, determine the MINIMUM SETTING of the OUTPUT CONTROL, at which the breaker under test opens immediately, whenever the INITIATE button is depressed.
12. Read and record ammeter reading as instantaneous pick-up of the breaker.
13. Repeat the above test for the other poles of the circuit breaker.
14. Shut down test set, disconnect breaker, and prepare for subsequent testing or relocation according to steps 19 through 23 in pre-test installation and setup outlined above.

### Instantaneous Trip Time Test

1. Perform Instantaneous Pickup Test as outlined above.
2. Adjust controls to obtain current above pickup, at approximate desired multiple of rating.
3. Close breaker under test.
4. Press the INITIATE button. Breaker should trip instantaneously.
5. Read and record timer and ammeter readings as instantaneous trip time and current.
6. Repeat the above test for the other poles of the circuit breaker.
7. Shut down test set, disconnect breaker, and prepare for subsequent testing or relocation according to steps 19 through 23 in pre-test installation and setup outlined above.

## **LOW VOLTAGE POWER CIRCUIT BREAKERS**

Nearly all low voltage power circuit breakers are multi-pole devices. The trip units may be either magnetic with a dash pot or solid-state electronic devices. Test procedures would be the same for either type. However, electronic trip types may incorporate ground fault protection. If so, it is necessary to either block or by-pass ground fault protection when tests are being conducted on phase fault characteristics. This is because the tests are being conducted on one pole at a time, and the ground fault protection would consider this operation to be a ground fault.

Most low voltage power circuit breakers have either Long Time Delay, and Short Time Delay, and/or instantaneous tripping characteristics. In this case, for test purposes, it is recommended that the instantaneous unit be set in its maximum calibration. This is to prevent an instantaneous trip while trying to set the current for the Short Time Delay characteristic.

Electrical tests to be conducted on low voltage power circuit breakers include timing test on L.T.D.; timing test on S.T.D.; and instantaneous pick-up. It is recommended that the magnitude of test current for the L.T.D. timing test be 3 times coil rating or transformer tap. For timing test on S.T.D. the test current should be about 1.5 times the S.T.D. setting. In both cases, tripping time should be within the manufacturer's published time range. Pick-up of the instantaneous unit should be +/- 10% of the setting for the electronic device and +/- 20% of the setting for the magnetic device.

Testing the instantaneous trip on very large circuit breakers set at or near maximum calibration may sometimes exceed the capacity of the test set. In most cases, the instantaneous element has several calibration marks between "LO" and "HI". In such cases, it may be necessary to perform the test at one of the lower calibration marks. Always be sure to record the "AS FOUND" settings and return the adjustments to these settings after testing. To perform testing, adjust the screw to a lower setting that allows the test set to verify that the unit will pick up. If the instantaneous unit picks up at the proper current at a lower calibration point, it may be assumed that the unit will operate properly at higher calibration points. This has been verified by manufacturers and by means of field tests.

Specific test procedures for all electrical tests are outlined on the following pages.

### **Timing Test, Long Time Delay**

1. Consult breaker manufacturer's literature to determine any necessary

## Electrical Test Instruments PI-800 GEN2 and PI-1600 GEN2

precautions and expected test results. A test current of three times the rating of the breaker should be used for this test.

2. Follow steps 1 through 17 in pre-test installation and setup, as required, to set up the breaker test set.
3. Connect appropriate output tap to one pole of breaker under test.
4. Setup MAC-21 for C.L. Maint (MAINTAIN on).
5. Set MAC-21 RANGE to lowest range that is greater than desired test current.
6. Set TIMEBASE to CYCLES.
7. Press PRESET key. Adjust preset time to 5.0 cycles. This value may be set higher or lower, depending on trip characteristics of breaker.
8. Press PRESET again to return to normal mode.
9. Select MEMORY mode.
10. Repeatedly jog the INITIATE button, while adjusting the OUTPUT CONTROL higher, until the desired test current is read on the ammeter. If insufficient current is obtained at maximum position of the vernier, set the OUTPUT TAP control to the next higher tap, return the vernier to zero, and continue.
11. Press RESET button.
12. Set TIMEBASE to SECONDS.
13. Select MAINTAIN mode.
14. If desired, N.C. mode may be used; connect contacts leads to an unused pole of the breaker.
15. Press and release INITIATE key; CLOSE or OUTPUT ON light should glow, timer should run, and current display should read desired output current.
16. While test is running, observe current reading. If necessary, adjust to correct value by using vernier control, or press MAINTAIN key for current hold.
17. When breaker trips, the test set output should de-energize, timer should stop, and OUTPUT ON light should turn off.
18. Read and record trip current and trip time. Compare to manufacturer's time/current curve. If necessary, adjust the trip unit and repeat the test.
19. Repeat the above tests for the other poles of the breaker, allowing time for breaker to cool. Note: Results are acceptable if all poles of the breaker trip within the manufacturer's time range for the value of test current chosen. All poles of the breaker need not trip in exactly the same amount of time.
20. Shut down test set, disconnect breaker, and prepare for subsequent testing or relocation according to steps 19 through 23 in pre-test installation and setup outlined above.

### Timing Test, Short Time Delay

Note: The breaker's trip time for short time delay will always be less than 30 cycles and may be as low as 4-5 cycles. Therefore, setting test current will require some practice. However, the magnitude of the test current is not critical; for instance, if the S.T.D. is set for 1000 amperes, there will be little or no difference in timing if a test current of 1500, 2000 or 2500 amperes is used.

Set up of controls is the same as for timing test L.T.D. Consult breaker manufacturer's literature to determine any necessary precautions and expected test results.

1. Follow steps 1 through 8 under Timing Test Long Time Delay.
2. Repeatedly jog the INITIATE button, while adjusting the OUTPUT CONTROL higher, until the desired test current is read on the ammeter. If insufficient current is obtained at maximum position of the vernier, set the OUTPUT TAP control to the next higher tap, return the vernier to zero, and continue.
3. Press RESET button.
4. Set TIMEBASE to SECONDS.
5. Select MAINTAIN mode.
6. If desired, N.C. mode may be used; connect contacts leads to an unused pole of the breaker.
7. Press and release INITIATE key; OUTPUT ON light should glow, timer should run, and current display should read desired output current.
8. Breaker should trip within 30 cycles (0.5 seconds). When breaker trips, the test set output should de-energize, timer should stop, OUTPUT ON light should turn off.
9. Read and record trip current and trip time. Compare to manufacturer's time/current curve. If necessary, adjust the trip unit and repeat the test.
10. Repeat the above tests for the other poles of the breaker, allowing time for breaker to cool. Note: Results are acceptable if all poles of the breaker trip within the manufacturer's time range for the value of test current chosen. All poles of the breaker need not trip in exactly the same amount of time.
11. Shut down test set, disconnect breaker, and prepare for subsequent testing or relocation according to steps 19 through 23 in pre-test installation and setup outlined above.

### Pick-Up of the Instantaneous Unit

## Electrical Test Instruments PI-800 GEN2 and PI-1600 GEN2

1. Consult breaker manufacturer's literature to determine any necessary precautions and expected test results. Note: If the instantaneous setting is such that the expected test result is above that which may be easily produced by the test set, a valid test may be performed by adjusting the setting to its minimum value. At the end of the test, restore the instantaneous setting to its specified value.
2. Follow steps 1 through 17 in pre-test installation and setup, as required, to set up the breaker test set.
3. Setup MAC-21 for C.L. Maint (MAINTAIN on).
4. Set MAC-21 RANGE to lowest range that is greater than desired test current.
5. Set TIMEBASE to CYCLES.
6. Press PRESET key. Adjust preset time to 5.0 cycles. This value may be set higher or lower, depending on trip characteristics of breaker.
7. Press PRESET again to return to normal mode.
8. Select MEMORY mode.
9. Repeatedly jog the INITIATE button, while adjusting the OUTPUT CONTROL higher, until circuit breaker trips instantaneously. This is the approximate pickup point. If insufficient current is obtained at maximum position of the vernier, set OUTPUT TAP control to next higher tap, return the vernier to zero, and continue.
10. Close breaker under test.
11. By repeating the test, determine the MINIMUM SETTING of the OUTPUT CONTROL, at which the breaker under test opens immediately, whenever the INITIATE button is depressed.
12. Read and record ammeter reading as instantaneous pick-up of the breaker.
13. Repeat the above test for the other poles of the circuit breaker.
14. If trip settings were modified for test purposes, restore them to their original values.
15. Shut down test set, disconnect breaker, and prepare for subsequent testing or relocation according to steps 19 through 23 in pre-test installation and setup outlined above.

### Instantaneous Trip Time Test

1. Perform Instantaneous Pickup Test as outlined above.
2. Adjust controls to obtain current above pickup, at approximate desired multiple of rating.
3. Close breaker under test.



## Electrical Test Instruments PI-800 GEN2 and PI-1600 GEN2

4. Press the INITIATE button. Breaker should trip instantaneously.
5. Read and record timer and ammeter readings as instantaneous trip time and current.
6. Repeat the above test for the other poles of the circuit breaker.
7. Shut down test set, disconnect breaker, and prepare for subsequent testing or relocation according to steps 19 through 23 in pre-test installation and setup outlined above.

## MOTOR OVERLOAD RELAYS

The motor overload relay is designed to provide overload protection for a motor; therefore, it offers only one time/current characteristic, which is essentially a long-time delay. It may be multi-pole; however, most relays are single pole. In the case of a multi-pole device each pole is tested individually as in the case of a multi-pole direct acting circuit breaker.

The motor overload relay contains two separate circuits. The current carrying circuit which contains the relay's operating coil or heater. The control circuit which contains a set of contacts; these contacts open when the relay "operates". It is the opening of these control circuit contacts that deenergizes the motor starter holding coils, thus allowing the starter contactors to open, shutting down the motor.

## Timing Tests

1. Consult the relay manufacturer's literature to determine any necessary precautions and the expected timing test results. The test current should be 3 to 4 times the rating of the relay operating coil or heater.
2. Follow steps 1 through 17 in pre-test installation and setup, as required, to set up the breaker test set.
3. Setup MAC-21 for C.L. Maint (MAINTAIN on).
4. Set MAC-21 RANGE to lowest range that is greater than desired test current.
5. Set TIMEBASE to CYCLES.
6. Press PRESET key. Adjust preset time to 5.0 cycles. This value may be set higher or lower, depending on trip characteristics of breaker.
7. Press PRESET again to return to normal mode.
8. Select MEMORY mode.
9. Connect the relay operating coil or heater circuit terminals to the breaker test set common terminal and the proper output tap terminal.

## Electrical Test Instruments PI-800 GEN2 and PI-1600 GEN2

10. Connect the relay control circuit contacts to the CONTACTS terminals and determine that they are closed by observing the CONTINUITY lamp.
11. Repeatedly jog the INITIATE button, while adjusting the OUTPUT CONTROL higher, until the desired test current is read on the ammeter. If insufficient current is obtained at maximum position of the vernier, set the OUTPUT TAP control to the next higher tap, return the vernier to zero, and continue.
12. Press RESET button.
13. Set MAC-21 to N.C. mode. Set MAINTAIN on.
14. Press and release INITIATE button; OUTPUT ON light should glow, timer should operate, and current should indicate on display.
15. When the relay control circuit contacts open, the test set output should deenergize and the timer should stop.
16. Read and record the test value of current and the time of the test. Compare the results to the manufacturer's specifications. If possible, adjust the relay. Usually, if the relay time of operation is incorrect, it is necessary to replace the relay heater with one of the recommended size for the motor being protected. If a check test is desired, the relay must be allowed to cool for a period of time (approximately 15 to 30 minutes).
17. For a multi-pole relay, repeat the above tests for the other relay poles.
18. Shut down test set, disconnect breaker, and prepare for subsequent testing or relocation according to steps 19 through 23 in pre-test installation and setup outlined above.

## RATIOING CURRENT TRANSFORMERS

To conduct a ratio test on a current transformer, a good multi-range bench ammeter is required in addition to the breaker test set. The breaker test set supplies primary current to the transformer and the bench ammeter is used to read the transformer secondary current. It is suggested that a graph of the test results be plotted. Primary current should be the abscissa and corresponding secondary current the ordinate of the graph.

**WARNING:** It is extremely important that the secondary circuit of the current transformer never be broken or opened while the primary circuit is energized. Should the secondary circuit of an energized current transformer be opened, the collapsing magnetic field generates an extremely high voltage across the open ends of the circuit until the resultant arc is extinguished. Under these conditions, personal injury and/or damage to the current transformer under test are probable.

1. Follow steps 1 through 17 in pre-test installation and setup, as required, to set up the breaker test set.
2. Connect the current transformer primary terminals to the breaker test set common terminal and the proper output tap terminal.
3. Connect the current transformer secondary terminals to the bench ammeter.
4. Set the MAC-21 to N.O. mode. Set MAINTAIN on.
5. Press and release INITIATE button; CLOSE or OUTPUT ON light should glow, timer should operate, and current should indicate on display.
6. Adjust OUTPUT CONTROL higher until the desired current transformer primary current is read on the MAC-21 ammeter. Adjust OUTPUT TAP switch, if necessary, to obtain required current.
7. Read and record the readings on both the breaker test set (MAC-21) and the bench ammeter.
8. Repeat steps 6 and 7 until the desired number of test points have been obtained. Note: It is suggested that test points be obtained in multiples of the current transformer rating. For instance, for a 200/5 current transformer, test points would be obtained at primary currents of 200, 400, 600, 800 amperes, etc.
9. Shut down test set, disconnect CT, and prepare for subsequent testing or relocation according to steps 19 through 23 in pre-test installation and setup outlined above.

## SECTION V

### SERVICE INFORMATION AND DOCUMENTATION

#### MAINTENANCE AND CALIBRATION OF THE PI-800 GEN2 and PI-1600 GEN2

The *PI-800 GEN2* and *PI-1600 GEN2* require only minimal maintenance. Mechanical components such as latches may need periodic lubrication. External surfaces should be kept clean, and screws on access panels should be checked for tightness. The output connectors must be kept clean and smooth, and bolts should be replaced if not in good condition. Poor output connections are the main cause of overheating and poor performance.

Occasionally, or more often if used in dusty environments, it is important to inspect and clean interior components. Disconnect from all sources of power, place the unit face down on a protective pad on panel handles, and remove the rear cover. Flip unit over with output connectors down. Remove the eight screws on the front panel, and carefully pull the entire unit up and out of the enclosure. Carefully blow out any dust and inspect all connections for tightness and any sign of deterioration due to corrosion or overheating.

The fans should be cleaned with a damp rag and checked for signs of bearing wear by spinning. Dust in the front panel screen should be blown out from inside with compressed air.

Vernier brushes should be inspected for signs of wear or overheating and cleaned or replaced as required.

Calibration of the *PI-800 GEN2* and *PI-1600 GEN2* requires accurate current measurement in both series and parallel connection. Adjustment may be accomplished by means of the potentiometers accessible through the chassis when the rear panel is removed. The pots correspond to the connection modes marked on the switch.

#### MAINTENANCE AND CALIBRATION OF THE MAC-21

The *MAC-21* is manufactured using solid state components that should not require extensive maintenance. However, the accuracy of the *MAC-21* is critical to the testing of circuit breakers, and is dependent upon the output of an air-core current sensing coil, which could change due to movement caused by shock or vibration encountered in transporting the test set. Other factors which may affect calibration are contact resistance in the control cable, unusual magnetic fields, insulation leakage, and aging of electronic components in the *MAC-21*. Therefore, proper operation and calibration should be checked at regular

## Electrical Test Instruments PI-800 GEN2 and PI-1600 GEN2

intervals and adjusted if proper equipment is available. The manufacturer's recommended calibration interval is (1) one year.

The inherently delicate nature of electronic circuitry and metering make it generally inadvisable to leave the **MAC-21** fastened to the breaker test set if it is being transported under conditions of extreme shock and vibration. The component parts should be disconnected, covers attached, and carried or shipped separately. Suggested periodic maintenance consists of the following:

1. Clean the lenses of the LED displays with a plastic cleaner.
2. Clean the front panel with a soft brush and cloth.
3. Perform basic field operational check as described below.

Field performance check of the **MAC-21** may be performed as follows:

1. Obtain a current measuring calibration standard capable of reading TRUE-RMS current up to at least 1000 Amperes to an accuracy of at least 0.25%.
2. Set up the breaker test set for normal breaker testing. If adjustments are anticipated, remove the **MAC-21** from the test set and remove the top cover.
3. Connect the calibration standard to the desired output tap. If cables are used, it is recommended that they be twisted so as to minimize radiation and pickup of stray magnetic fields.
4. Apply power to test set and allow at least one minute for circuits to stabilize.
5. Check ammeter zero in all ranges. If reading on current meter is greater than 1% of Full Scale, internal zero adjustment may be required.
6. Set **MAC-21** Range to 1000 A and adjust output of breaker test set to exactly 800 Amperes. If Coarse Tap is 1, and Output Control Vernier is less than 50%, additional resistance must be added to output circuit. This is important, because waveform distortion is more prevalent at lower levels.
7. If the **MAC-21** reading differs from the standard by more than rated accuracy, adjust the gain potentiometer for proper reading.
8. Check accuracy at 200, 400, 600, and 1000 Amperes.
9. Adjust the current to zero, and press RESET key.
10. Raise the current slowly, until the timer begins to run. This is the Current Latch Threshold, which should be about 5% of full-scale range.
11. Set the current at 50% of full scale (500 A) and stop the current.
12. Set the **MAC-21** to MEMORY mode and press the RESET Switch.
13. Initiate a fast-momentary pulse of no more than 6 cycles (0.1 Sec) duration.

## Electrical Test Instruments PI-800 GEN2 and PI-1600 GEN2

The meter should read the same value, within 2%, that was set in step 11 above.

14. Check pulse reading operation in this manner for currents of 200, 400, 600, and 1000 Amperes, and varying duration.
15. Set Timer Time base to SECONDS. Press Master Reset Switch. Set N.O. mode. Using a timing standard, initiate for exactly ninety (90) seconds. Timer should read 90.00 Seconds, +/- 0.01 Seconds. (Note: actual reading may vary because of inability to control and measure pulse length.)
16. If everything checks out, the **MAC-21** can be assumed to be in calibration, and no other adjustments are required.

## Electrical Test Instruments PI-800 GEN2 and PI-1600 GEN2

### PARTS LIST (PI-800 GEN2):

The overall schematic is at the end of the manual. The parts list is provided below. Please refer to both when ordering replacement parts.

ITEM	QTY	DESCRIPTION	REF DES	ETI Number
1	1	Contactora, 4PST, 30A	K1	M-C197
2	2	Contactora, 2NO2NC, 20A	K2-K3	M-C196
3	1	Relay, 4NO, 12 VDC	K4	M-E104
4	1	Relay, voltage sensing, 0-280 VAC	K5	S-B183
5	1	Relay, DPDT, 12 VDC	K6	M-C149
6	1	Switch, Input Selector	S1	M-C203
7	1	Switch, Tap Selector	S2	M-C204
8	1	Switch, Pushbutton	S3	M-C214
9	1	Programmable Overload Device (POD)	M1	S-B154
10	1	Transformer, 240/120 VAC	T7	M-E136
11	2	Fuse, 250V, 60A, FRN-R60	F1, F2	M-C168
12	3	Fuse, 250V, 2A, MDL-2	F3, F4, F5	M-B178
13	1	Connector, Female, 14 pin	J1	M-C199
14	2	Connector, Jack, Male, 50A, Red	J3, J4	M-C428
15	1	SCR Ass'y, 90A	SCR1	M-C202
28	1	SCR Trigger PCB Ass'y	PC1	S-B380
29	2	Fan, 80mm, 12 VDC	B1, B2	M-C274
30	2	Fan Guard, 80 mm	B1, B2	M-C205
31	8	Output Terminal		M-D165
32	30	Pin, female, #24-20	J1,P1	M-A128
33	3	Pin, female, #10	J6	M-C272
34	1	LED, red, 12V	DS2	M-B251
35	1	Fuse Holder, 300V, 60A	F1, F2	M-C169
36	3	Fuse Holder, 300V, 30A	F3, 4, 5	M-B177
37	2	Series Bar, Inner		M-D166
38	2	Series Bar, Outer		M-D167
39	1	Output Bar, 800 A		M-D168
40				
41	1	Power Supply, 12 VDC		M-E101
42	1	Thermistor, 10k	TH1	M-B226
43	2	Vernier Deck, 140V, 10A	T1, T2	M-E141
44	1	Transformer, Parallel	T3	M-C277
45	1	Transformer, Toroid, 120 V	T4	M-E138
46	2	Transformer, Toroid, 140 V	T5, T6	M-E139
47				
48	2	Connector, plug, female, 50A	P3, P4	M-C432
49	1	Connector, rec, female, 3 pin	J6	M-C270
50	4	Connector, terminal block, 10 pos	TB1-TB4	M-C127
51	1			
52	1	Switch, 3P, 4Pos	S7	M-C212
53	1	Lamp, Neon, Red	DS13	M-B322
54	2	Lens, Red		M-C112
55	2	Lens, Green		M-C113
56	1	Lens, Yellow		M-C114

## Electrical Test Instruments PI-800 GEN2 and PI-1600 GEN2

### PARTS LIST (PI-AUX):

The overall schematic is at the end of the manual. The parts list is provided below. Please refer to both when ordering replacement parts.

ITEM	QTY	DESCRIPTION	REF DES	Part Number
1	4	Contactora, 2NO2NC, 20A	K1-K4	M-C196
2	1	Plug, 3 pin, #10, Male		M-C561
3	1	Connector, 14 pin, male		M-C134
4				
5	2	Fan, 80mm, 12 VDC	B1, B2	M-C274
6	2	Fan Guard, 80 mm	B1, B2	M-C205
7	8	Output Terminal		M-D165
8	4	Transformer, Toroid, 140 V	T1-T4	M-E139
9	3	Pin, male, #10	J1	M-C273
10	4	Snubber	K1-K4	M-B278
11	2	Handle, brass, nickel plated, 3"		M-C174



PI-800 GEN2 Output Connections

4.5 Volt 800 Amp

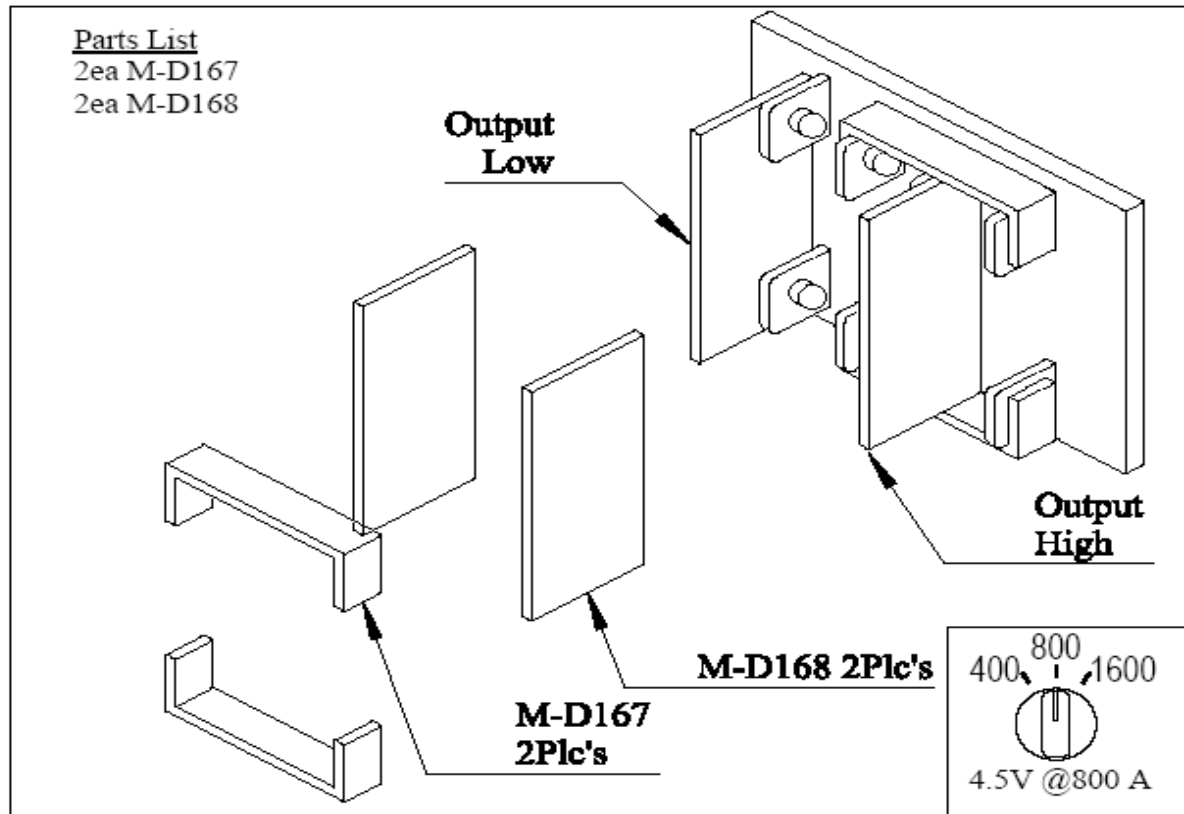

PI-800 GEN2 Output Connections

9 Volt 400Amp

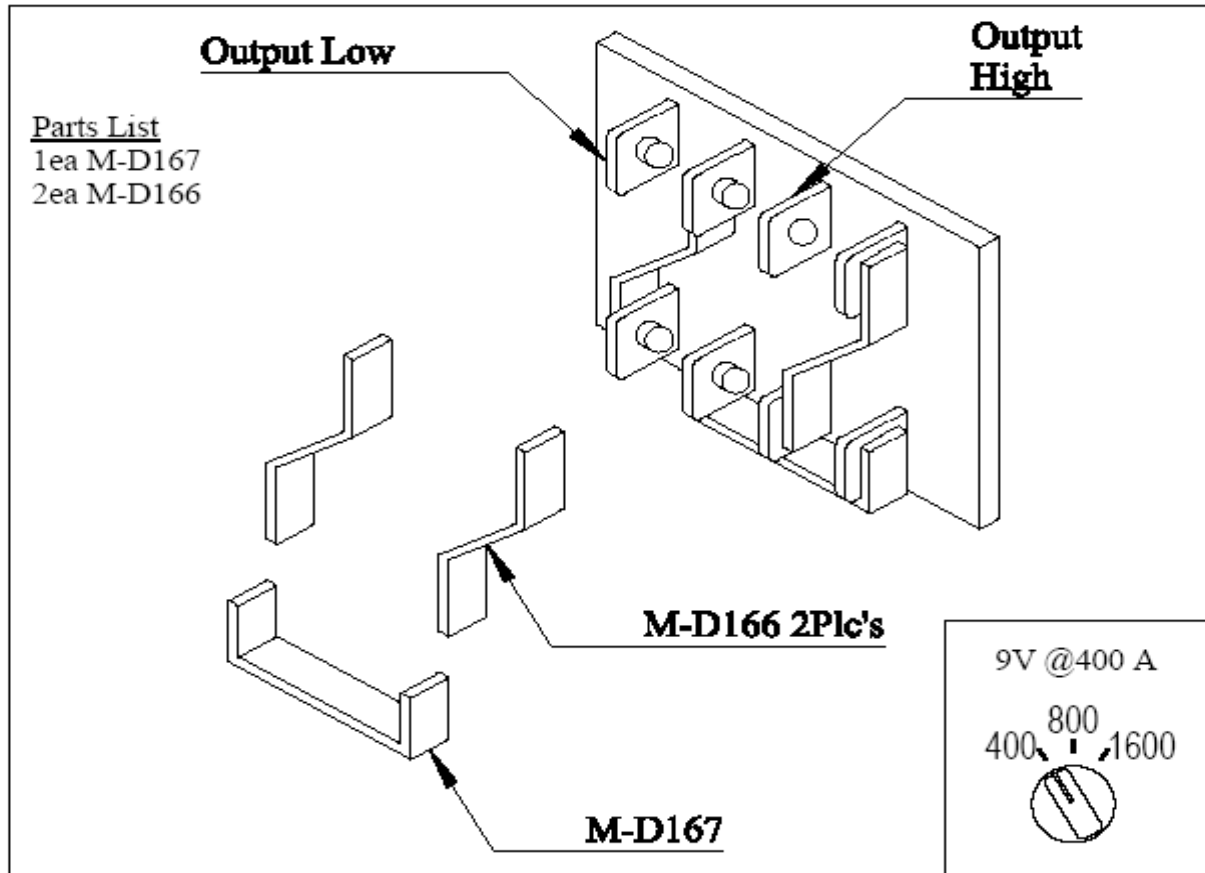

PI-1600 GEN2 Output Connections

10 Volt 800Amp

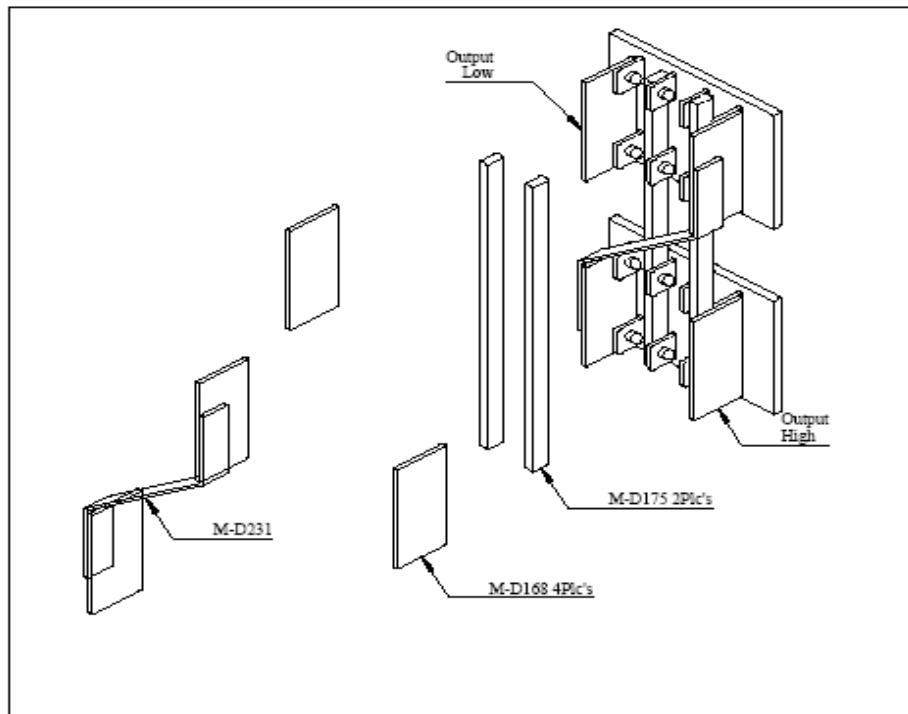

Parts List

2ea M-D175

4ea M-D168

1ea M-D231

10V @800 A

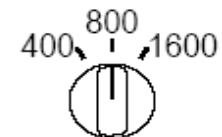

PI-1600 GEN2 Output Connections

5 Volt 1600Amp

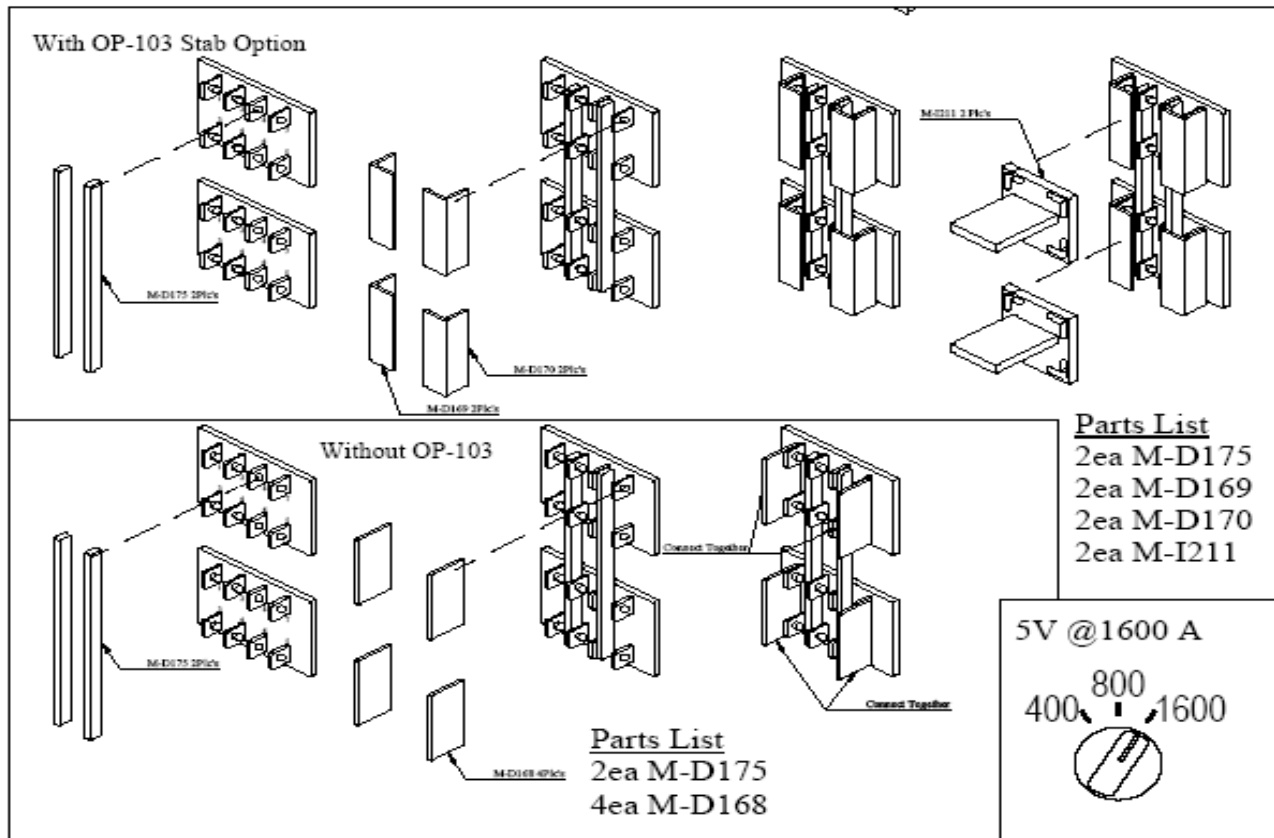

**Electrical Test Instruments PI-800 GEN2 and PI-1600 GEN2  
WARRANTY**

Electrical Test Instruments, LLC, will correct any defect in workmanship or material for two years after date of purchase of any Electrical Test Instruments product. Such corrective measures will be limited to repairing or replacing the unit, at Electrical Test Instruments' option. This limited warranty shall not apply to equipment which has been subjected to negligence, accident or damage by operation, maintenance or storage, or to non-normal use or service. This limited warranty does not cover reimbursements for transportation, removal, installation, repair or replacement, except as may otherwise be specifically agreed to in writing by Electrical Test Instruments. The foregoing is in lieu of all other warranties expressed or implied, and all other obligations or liabilities whether arising under contract, negligence or otherwise, on the part of Electrical Test Instruments. In no event shall Electrical Test Instruments be liable for consequential or special damages, including but not limited to loss of use, loss of income, loss of profit or cost of replacement.